



## GO<sup>2</sup> WorkCenter Assembly Manual

---

section one  
workcenter assembly

---

# TABLE OF CONTENTS

## section one – workcenter assembly

Tools/Hardware.....	4
Components.....	5
Frame Layout.....	5
Feet Assembly.....	6
Resetting Control Panel.....	7
Gas Spring Preperation.....	8
Attaching the Table Top.....	9

## section two – accessory installation

Tools/Hardware.....	11
Preparing the Table Top.....	12
Attaching Accessories	
Mounting Rail Posts.....	16
Mounting Rail.....	16
Mounting Rail Accessories.....	17
Mounting Table Top.....	17
Accessories	
Mounting Table.....	19
Frame Accessories	
Mounting CPU.....	20
UPS Holders	
Rail Mounted Light.....	22
Assembly	
Contact Information.....	25
and Assistance	

---

## TOOLS NEEDED FOR WORKCENTER ASSEMBLY

- Phillips & flat head screwdriver
- #1 Phillips Bit
- Metric Allen wrenches 2-8mm (Long T-handle 4mm helpful)
- Wrench or socket 7, 8mm
- Torx head screwdriver T25

## HARDWARE LIST FOR WORKCENTER ASSEMBLY

### FRAME



Column Mounting Plate screw T25 20mm  
(4 at each end of each column-already installed)



Table Top mounting Allen bolt 5mm (or 4mm) x 25mm  
(8) - supplied

# 1. COMPONENTS

## Box (A) Frame and optional accessories

## Box (B) Table top, Support Structure, Cable Outlets (3)

Unpack and layout all components from box (A). All the fasteners are in individual bags taped to the relative component.

- (A) Frame
- (B) (2) short feet, (2) long feet

Options:

- (C) Monitor rail
- (D) (2) monitor rail posts
- (E) Cable Tray with or without MBMOU and power strip
- (F) Accessory Boxes

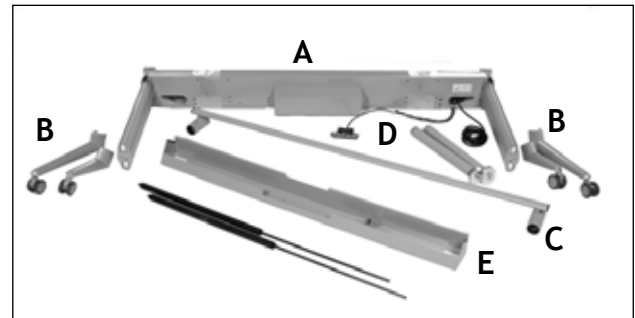
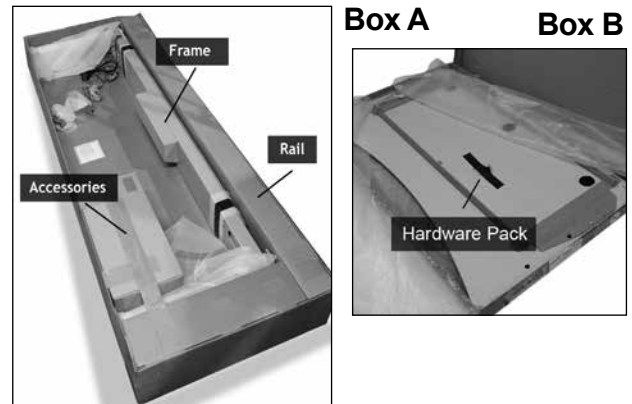

# 2. FRAME LAYOUT

- Lay frame upside down. The control panel cable always exits the cross rail at the back of the frame.
- Motor housing is flush with the back side of frame. The angled side is the front of the frame.
- The short legs always attach at back of frame. The long legs always attach at front of frame.

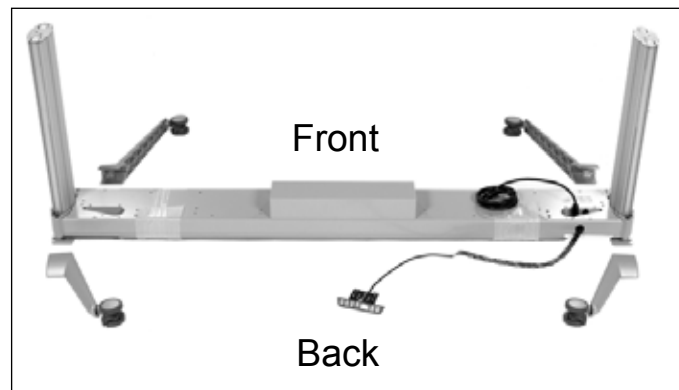

### 3. FEET ASSEMBLY

- Using 4mm long T-handle Allen wrench, loosen but do not remove completely, Allen bolts on foot binding clamp. (pic. 1.)
- Align foot and binding clamp in grooves of leg (pic. 2) and slide down to the numbered markings. (pic. 2a)
- (pic. 2a) The top of the foot (when frame is turned upright) should stop on the line between zero (0) and one (1). This sets the minimum table height to 68cm (26.75") and will allow for adequate bottom of frame clearance for most flooring surfaces including carpet.

**NOTE:** *If customer requests a change in height, you may line up the feet on higher numbers if you want the minimum table height to be greater than 68cm. (26.75")*  
*Each mark represents one (1) cm.*  
*Total range is 10 cm or 4".*

*Be careful to line up all four feet to the same number as to make sure the workcenter is level. (pic. 4)*

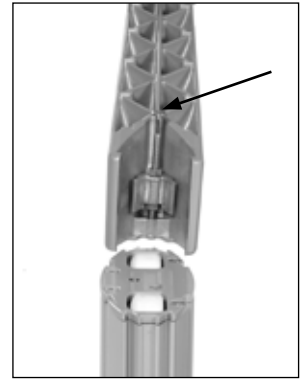

pic. 1

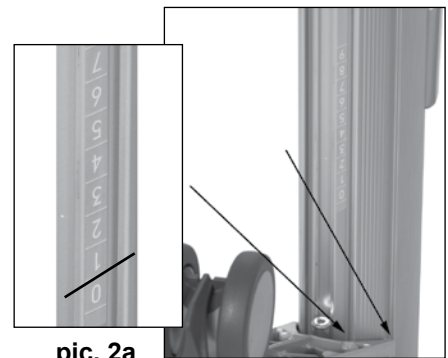

pic. 2a

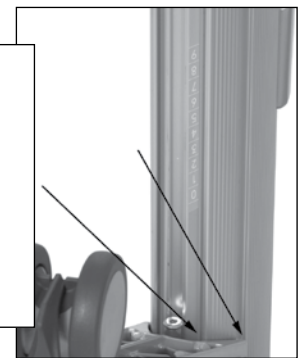

pic. 2



pic. 3



pic. 4

## 4. RESETTING THE CONTROL PANEL

- Keeping frame upside down, plug desk in. You will see blinking zeros on the control panel. (pic. 1)
- To reset the control panel, press and hold the down arrow button until column reaches its lowest position. Continue to press the down arrow until display reads 067 or 068. The workcenter controls are now reset.

**NOTE:** *You cannot raise the table until you reset the column at its lowest position.*

**YOU ARE NOW READY TO RAISE THE TABLE ASSEMBLY USING THE UP ARROW (^).**

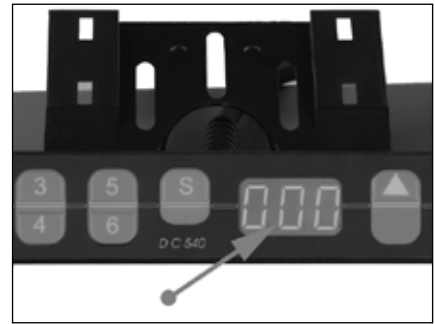

pic. 1



pic. 2

## 5. GAS SPRING PREPARATIONS (not applicable if factory installed)

- Extend the leg columns completely by pressing and holding the “up” arrow until top reaches 120cm shown on display. (pic. 3)
- Remove the cover (stabilizing plate) on the foot side of the column by loosening the four (4) counter sunk screws. (pic. 4)

**THE COLUMNS HAVE TO BE COMPLETELY EXTENDED BEFORE INSTALLING GAS SPRINGS BECAUSE OF THE RISK OF INJURY BY THE PRESSURIZED GAS!**

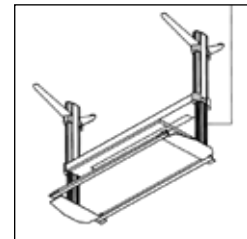

pic. 3



pic. 4

## 6. INSTALLATION OF GAS SPRINGS (not applicable if factory installed)

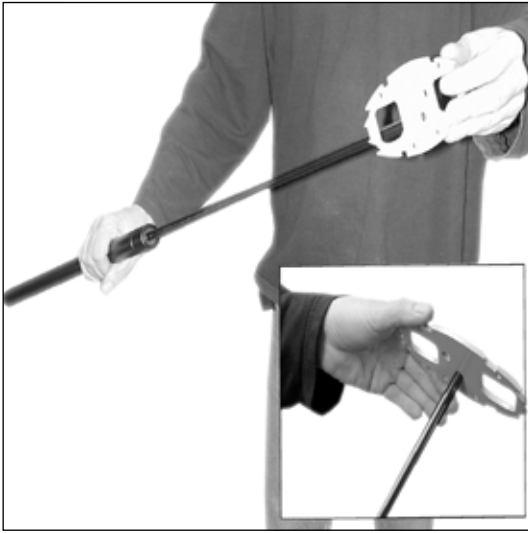

pic. 1



pic. 2

- Align the stabilizing plate with the piston rod of the gas spring side of the plate with countersunk holes facing away from spring.. Plate has to be rotated clockwise on the piston rod to secure. (pic.1)
- Center gas spring with stabilizing plate into column and align plate with (4) screw holes.
- Mount the plate (pic.2) using the four (4) Torx head countersunk screws and Torx25 tip. Tighten screws **evenly** to compress cylinder until plate is flush with leg column.

**Note:** *Tighten screws slowly in an alternate pattern making sure plate compresses evenly.*



## 7. ATTACHING TABLE TOP

**NOTE:** IF THE MODEL NUMBER ENDS IN Z OR ZM: AFTER THE GAS SPRINGS ARE INSTALLED, THE FRAME HAS TO HAVE APPROXIMATELY 88 LBS OF WEIGHT ADDED WHILE RAISING OR LOWERING THE TABLE ASSEMBLY.

*(TO ADD WEIGHT, LEAN ON FRAME, EXERTING APPROXIMATELY 88 LBS OF PRESSURE WHILE PRESSING AND HOLDING THE UP OR DOWN ARROW.)*

**CAUTION:** FAILURE TO DO THIS MAY DAMAGE MOTOR OR GEARS.

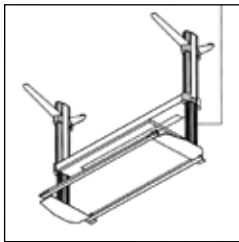

pic. 1

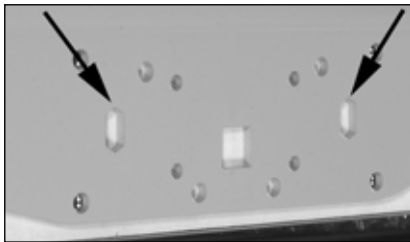

pic. 2



pic. 3



pic. 4

- Align frame with top support structure and attach columns to top (pic 2 with pic 3) with supplied (8) #4 Allen head bolts- 4 per column.

**Note:** *When table top and columns are aligned, the two plates will be flush.*

**\*Jobsite Conditions:**

A. If you are assembling the workcenter **in the room where it will reside**, you can assemble the entire unit upside down and then place right side up.

B. If you are assembling the workcenter **outside of the room where it will reside**, the control panel cannot be attached to the top until the table top and leg assembly are placed in the final room location

---

section two  
accessory installation

## TOOLS NEEDED FOR ACCESSORY INSTALLATION

- Phillips head screwdriver
- #1 Phillips Bit
- Metric Allen wrenches 2-8mm (Long T-handle 4mm helpful)
- Wrench or socket 7, 8mm

## Hardware List- section two



Rail Post mounting Allen bolt 6mm x 50mm  
(4) - supplied



Rail Post mounting Allen set screw  
(4) - supplied/installed



Phillips 3/4" wood screw used for (Light Ballast) (4),  
-unless Generation II Cable Tray is used.  
Cup Holder (3)



Phillips 1 1/2" wood screw Light Control switch box(2)



Wire management clips (for Control Panel Cable)

# 1. PREPARING TABLE TOP

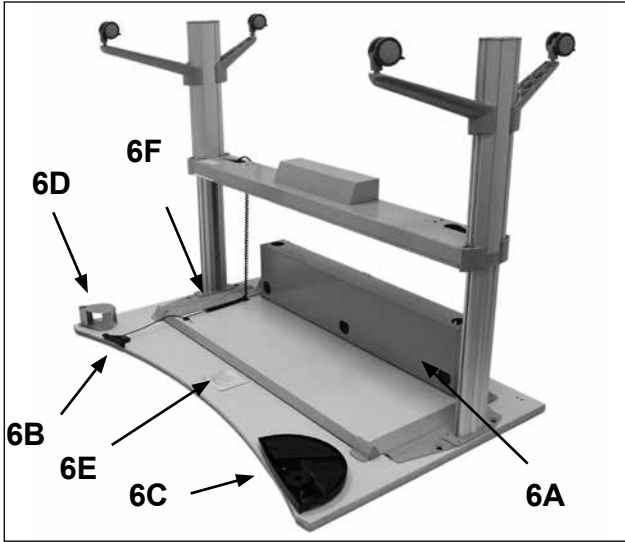

pic. 1

- 6A Multi-Outlet Strip/Cable Tray  
**Generation II**
- 6B Control Panel
- 6C Pencil Tray
- 6D Cup Holder
- 6E User's Manual
- 6F Wire Management

- Pic. 1 shows position of all standard, optional accessories attached to the bottom of the table top and of user's manual placement location.
- Open Box B (table top) with finished top facing down, exactly as shown in pic.1; this makes for easier installation of accessories and frame (space permitting).

**Note:** *Pre-tapped holes are used to aid in accessory placement on underside of top.*

## 1A - Multi-Outlet Strips & MBMO-U

MBMOU is an adapter plate used to mount power strips to Generation I Cable Tray. The 2 Duplex and 4 Duplex can also be mounted to the Generation II Cable Tray using the MBMOU mounted to the slotted door of the cable tray.

- Mount in cable tray as seen in pic. 2 and in Generation II as seen in pic. 2A  
Use plastic thumbscrews to secure. (pic. 2B)



2-Duplex



4-Duplex



pic. 2A

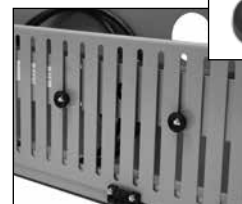

pic. 2A



pic. 2B

- Mount 6-Duplex Multi-Outlet strip in Generation II cable tray as seen in pic. 3.  
Use screws to secure. (pic. 3B)

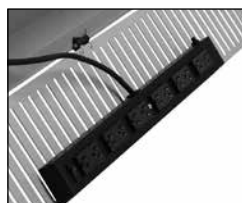

pic. 3

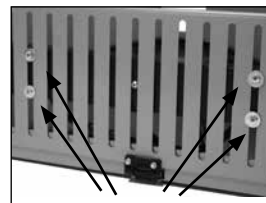

pic. 3A

6-Duplex  
with Generation II Cable Tray  
no MBMO-U required

## 1A-1 - Cable Tray- Generation I



pic. 3

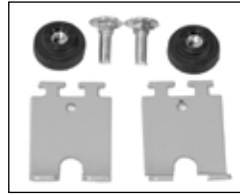

pic. 4



pic. 5

- Position cable tray as seen in pic. 3 and pop tray into place by slide lip of cable tray under triangular tube.
- Use mounting brackets (2) (Pic. 4) and nut/bolts to secure tray to triangular tube. (Pic. 5)

## 1A-2 - Cable Tray- Generation II

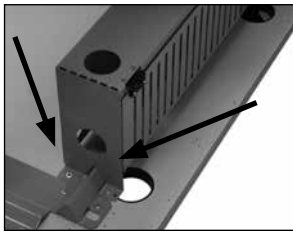

pic. 6

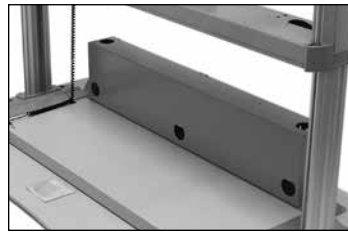

pic. 7



pic. 8

- Center cable tray over triangular tubes with the hinged door facing toward the rear of desktop. (Pic 6)
- Center cable tray left and right of desktop. (Pic 7)
- Attach using the 3/4" wood screws. (Pic 8)

## 1. PREPARING TABLE TOP cont.

### 1B - Preparation for the Control Panel

**Note:** *The control panel cannot be installed or secured to the top until top is mounted to the frame and workcenter is in its final location. Be sure control panel cable comes from behind and over cross rail.*

- Locate the pre-marked holes for the control panel mounting plate. Pre-drilled holes should allow this.
- Position control panel mounting plate at pre-marked holes (pic. 6). This bracket allows the control panel to slide approx. one inch front to back
- Place control panel on top of mounting slide plate and position control panel so that when slid to front of plate, the panel is flush with front edge of table top.
- Fasten with supplied (3) Phillips head screws using #1 Phillips bit **ONLY**.

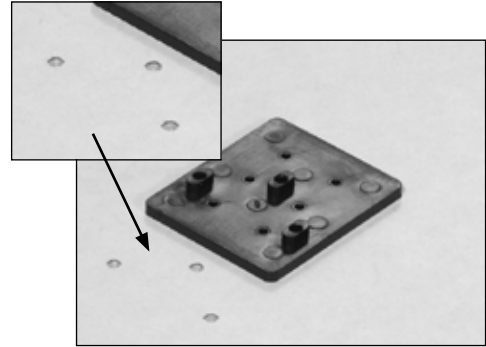

pic. 6

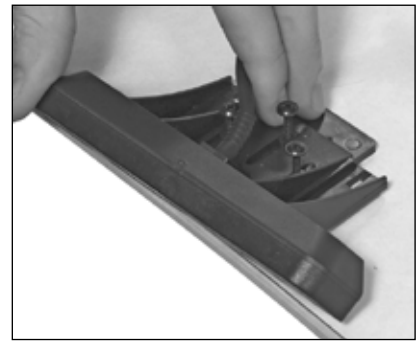

pic. 7

**Note:** *Caution should be used not to strip the #1 Phillips head screw.*

**CAUTION: DO NOT OVER TIGHTEN. CONTROL PANEL WILL NOT SLIDE.**

### 1C- Pencil Tray

- Use the 2 holes located on front edge of top, the opposite side from the control panel. see Pic 8

**CAUTION IS NEEDED AS TO NOT OVER TIGHTEN SCREWS. OVERTIGHTENING SCREWS MAY CAUSE THEM TO PUNCTURE LAMINATE ON DESK SURFACE**



pic. 8



## 1. PREPARING TABLE TOP cont.

### 1D - Cup Holder

- Attach cup holder at pre-tapped holes on the under side of top, left or right corner, with supplied (3)-3/4" Phillips head wood screws.

**Note:** *Preferable location is the opposite side of the CPU placement.*

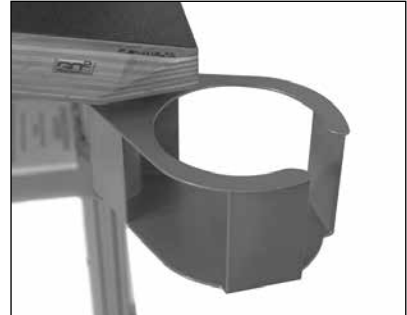

pic. 10

### 1F- User's Manual

- User manual is located in the Frame Box. (Pic 11)
- Remove film backing from packet and apply packet on underside of table where indicated in pic.12.



pic. 11

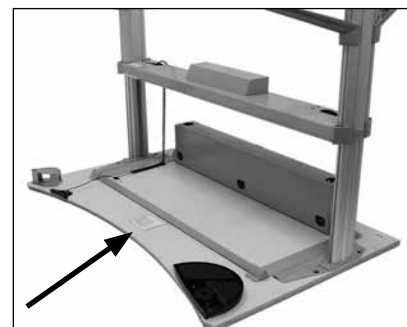

pic. 12

## 2. MOUNTING RAIL POSTS

**CAUTION:** *Rail and Rail Accessories can not be installed until table top is attached to leg assembly and placed upright.*

- Post should be mounted on table top with 4 supplied 6mm allen head bolts.
- Place one full washer on table top surface and the second half washer on the underside of the table top. (Pic 2 and Pic 3)

**Note:** *DO NOT tighten posts completely until rail is positioned on posts (step 2).*



pic. 1



pic. 2

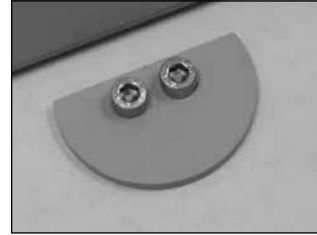

pic. 3

## 3. MOUNTING RAIL

- Pic. 1 shows position of installed rail and posts.

**NOTE:** *Rail may be mounted in front or behind support posts.*

**CAUTION:** Loosen 2.5 mm allen screws (A-pic 2) and the 2 mm allen screw (B-pic 2) so that they are recessed from the inside of the rail collar or damage to post could occur.

- Slide rail down evenly over rail posts so that the bottom of rail collar is even with the 2nd to last ring at the bottom of post, approximately 10cm from work top.

**Note:** The rail height is determined by the size and style of monitors. A good starting position is to place the collar at the second ring from the bottom of the rail posts, approximately 10cm from the work top. It is also important to position the rail collar on one of the post rings so the set screw A in Pic 3 will fully tighten on the post.

- Tighten set screws carefully, not to over tighten.
- Once rail is positioned on post, finish tightening the bolts securely on the post under the top (step 1).



pic. 1



pic. 2

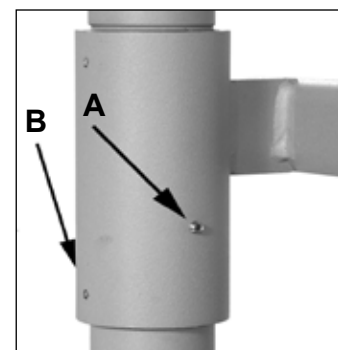

pic. 3



## 4. MOUNTING RAIL ACCESSORIES

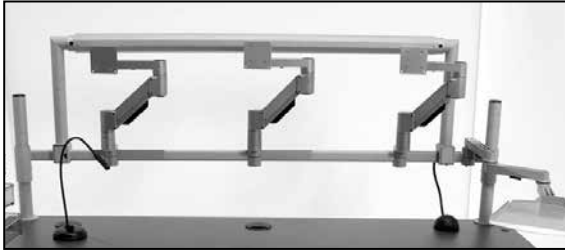

pic. 1

**NOTE:** Pic 1 shows how the accessory arms should be spaced equally across rail.



**A. Advanced Height Adjustable Arm**

model # 3500-250/450/800-RF

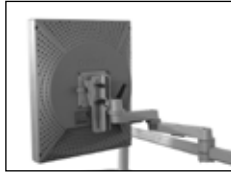

**B. Manual LCD holder**

model # LCD-QRE-RF



**C. Phone Post**  
TSA-RF

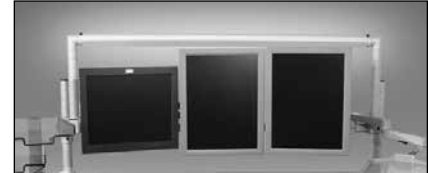

**D. WLTC Indirect Light**  
See Section 7

### 4A. Mounting Advanced Height Adjustable Arm



pic. 1A



pic. 1B



pic. 2



pic. 3



pic. 4

- Place accessory on rail in approximate final location. Secure “V” clamp with 2, #4 Allen head bolts. (pic.1A- in front; 1B in back)
- Attach 100mm VESA plate to monitor using same 4 screws supplied with monitor or the 4 longer **BLACK** screws supplied with each Advance Height Adjustable Arm (pic. 2)

### 4B. Mounting Third Rail Support Post

- Place accessory on rail in approximate final location. Mark screw locations. (pic 1)
- Drill holes in desktop for each screw. (pic 2)
- Attach post with supplied #4 Allen Bolts (pic 3) and half washer on bottom (pic 4)



pic. 1

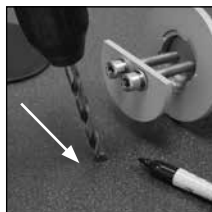

pic. 2



pic. 3



pic. 4

## 4B. MOUNTING MANUAL HEIGHT ADJUSTABLE ARM

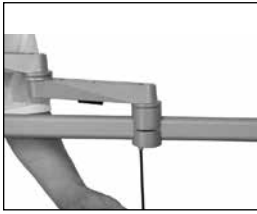

pic. 1

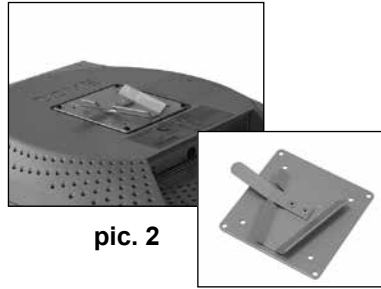

pic. 2



pic. 3

- Place accessory on rail in approximate final location. Once in final location completely secure by securing “V” clamp with 2- #4 Allen head bolts.
- Attach 100mm VESA plate to monitor using screws supplied with monitor. (pic. 2)
- LCD Holder quick release plate:  
Slide monitor with plate into quick release receiver on the end of the monitor arm. When firmly seated, the release arm on the VESA will lock into place into the receiver. (Pic 3) (shown without monitor)

## 5. MOUNTING TABLE TOP ACCESSORIES



pic 1



pic 1A



pic 1b

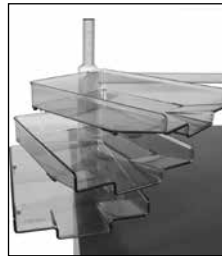

pic 1C\*



pic 1D

- Remove organizational hole cover. (pic 1)

1A - Remove cap & sleeve of org. hole. Position Desk Fixing Post w/ full washer over org. hole. Insert bolt and small washer from under desk into top with 300 mm post.

Applicable with:

1B - Telephone Post Holder

1C- Paper Tray \***Note: Org sleeve does not need to be removed**

1D - LCD Arm - Manual Height Adjustment (LCD-QRE-DF)

**INSTALLATION NOTE:** *Paper tray and Advanced LCD Height Adjustable Arm can also be mounted to the desk top with optional desk clamp.*

**NOTE:** *Step by step installation of triple paper tray in box. Desk Edge Clamp not applicable when using org. holes.*

## 6. MOUNTING POWER DOME

- Remove grommet hole cover.
- Insert wires of power dome through grommet hole (pic 1)
- Slide both halves together and place in grommet hole until flush with desk top (pic 2)



pic 1



pic 2

## 7. CPU/LINE CONDITIONER INSTALLATION

- The GMCZ-6 comes with one connecting column and one Support Plate for complete set up. (pic.1)
- 1. Determine the width of your CPU case. Loosen the two black thumb screws on the side to extend the standard support plate-but do not extend beyond the thumb screws. If the CPU is wider than 5 1/4" then you will need to add the extensions that come stored under the support bracket. This will give you a maximum width of 11". (pic 2)

To add the extensions remove from below storage area and remove the factory installed outside support plate and turn to the underside. Remove the #2 Allen head set screws with the supplied Allen wrench. Insert the smaller end of the extensions, hole for the set screw facing down, into the standard tubes. Replace the set screws, insert the end caps from the accessory pack and replace the support bracket. Adjust to width of CPU and tighten thumb screws. (pic 3)

- 2. Mounting the GMCZ-6 on the workcenter leg.(pic 4)

This can be mounted to the outside of either leg on the work-center, preferably, out of foot area. If mounted inside, then the maximum height of the CPU case cannot exceed 20 3/4" due to the crossbar of the desk frame. Once this is determined, use the supplied #4 Allen wrench to tighten the clamp to the leg profile of the leg at the highest point on the leg.

- 3. An additional Support Bracket (pic 5) can be ordered to stack multiple or a mix of CPUs and UPSs. Measure the height of the piece that will sit in the bottom support to determine where the height of the additional support will be located.
- 4. The Accessory Pack (pic 3) also contains rubber leveling bumpers. Normally, 3 large ones spaced evenly on the outside support ledge will adjust the CPU to level. (pic 4a)

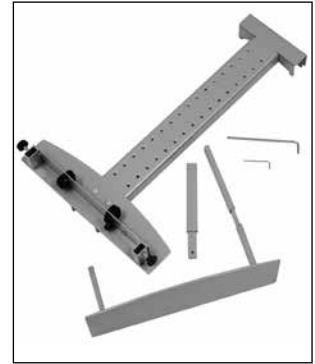

pic 1



pic 2



pic 3



pic 4

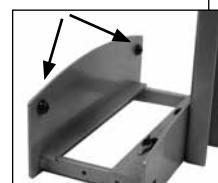

pic 4a



pic 5

## 7.1 GMZC6 SPE INSTALLATION

- After assembly of the GMZC6, if necessary install the GMCZ6 SPE accessory.

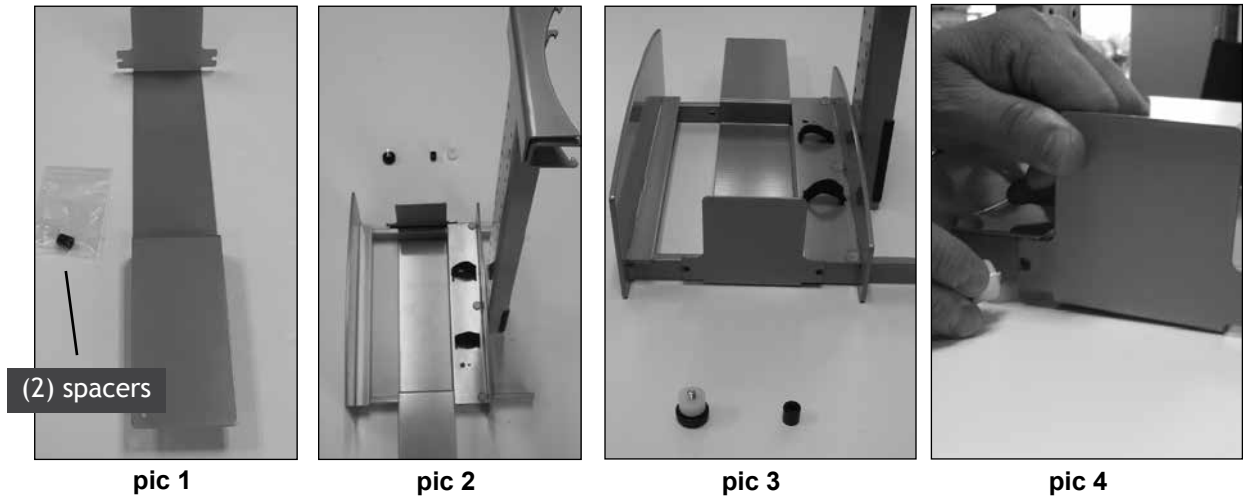

- Remove SPE accessory from box including bag with (2) spacers as shown (pic. 1)

**NOTE:** *When mounting GMZC6 IN-BOARD in conjunction with the NEW eisys HINGED CABLE TRAY, the SPE accessory **MUST** be installed to protect the CPU from cable tray collision when lowering the desk.*

- Install SPE as shown, once you have set the proper width of the SP for your particular CPU tower (pic. 2)

**NOTE:** *The SPE slides under the SP rear rod and over the front rod.*

- Next select the appropriate spacer to allow secure tightening of the SPE to the SP rear extension rod (pic. 3)
- Align and finger tighten knurled screw with spacer. After final placement of CPU in holder, finish tightening both knurled screws to their final secure position (pic. 4)

- Finished product should be as shown (pic. 5)

**NOTE:** *opposite side installation is identical.*

pic 5

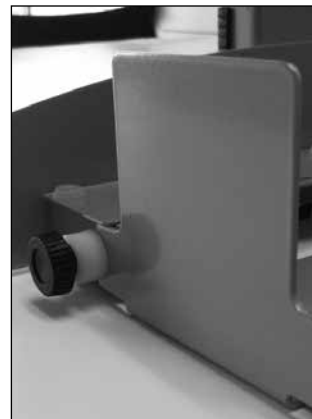

## 8. ASSEMBLY OF RAIL MOUNTED LIGHT- WLTC

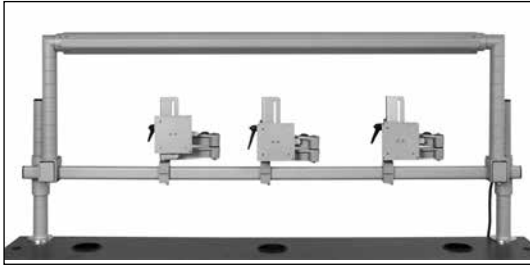

Shown from front with shield rotated to aim light on wall. Shield may be rotated as desired to aim light in any direction.

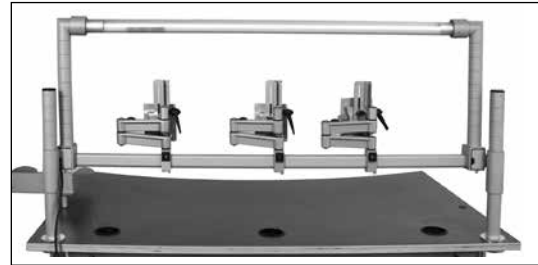

Shown from back with shield removed.

### TOOLS NEEDED FOR ASSEMBLY

Phillips head screwdriver

Allen wrench 5 mm

### 8.1 COMPONENTS

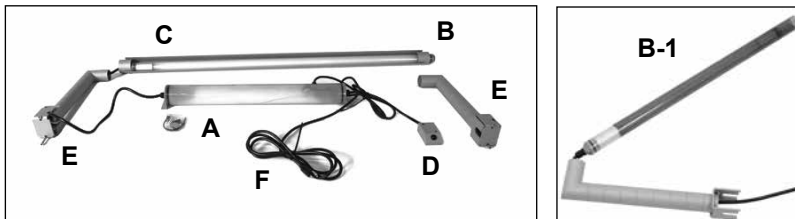

- (A) Ballast Housing w/ ballast (4- 3/4" Phillips Head wood screws)
- (B) Light shield (B-1) Optional Blue Lens
- (C) Fluorescent lamp & cable
- (D.1) Desk mounted switch box (2- 1<sup>3/4</sup>" Phillips Head wood screws)
- (D.2) Switch and cable
- (E) Light posts (2) w/ clamps (4- #5 Allen Head screws)
- (F) Power cable
- (G) Black Nylon Knurled Screws for Light Shield Tension (2) (not pictured)

## 8.2 Position lamp in post ends

- **Pic.1** - Insert lamp ends into posts until seated.
- **Pic.2** - Shows lamp correctly seated.



pic. 1

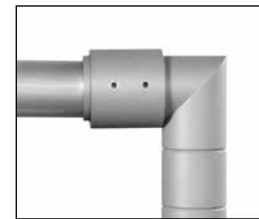

pic. 2

## 8.3 Attach support posts to rail

- Attach light posts using the bottom clamps and Allen bolts finger tight.
- Feed lamp power cord through rear slot in clamp. Standing behind the desk, the cord should come through the left post.

Mount swivel clamps so that posts can be mounted in any location on a corner desk with a curved monitor rail.

**NOTE:** *Light post should be centered and vertically straight.*

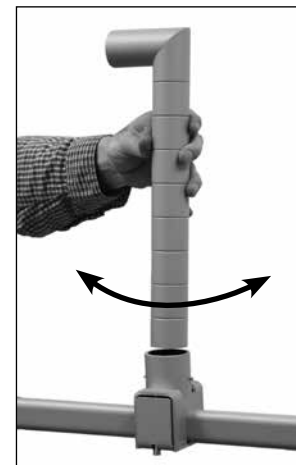

pic. 1

## 8.4 Mounting the ballast housing

- Desktop Mounting:  
Use the supplied 4 wood screws.  
Locate the 4 predrilled holes, centered, just forward of the rear triangular tube. **(Pic 1)**  
Attach ballast here.
- Cable Tray Mounting:  
**(for Generation II Cable Trays only)**  
Use the supplied 4 bolts and thumbscrews.  
Insert in the 4 holes located in the bottom of the cable tray. Tighten.  
**(Pic 2)**



pic. 1



pic. 2

## 8.5 Attach power switch to desktop

- Locate the two pre-tapped holes under desk top and to the right of control panel.
- Attach switch box to bottom of desktop with two (2) 1 3/4" wood screws provided. **(Pic 1)** Switch box should be flush with front edge of top.
- Manage wires with provided wire clips.

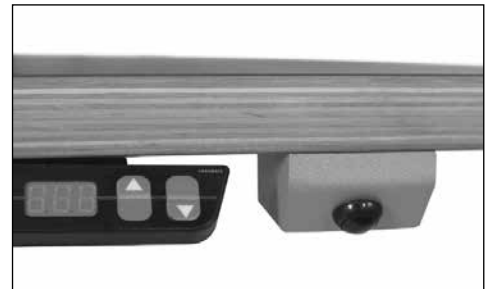

pic. 1



---

Heavy Duty  
Height Adjustable Arm  
with 3rd Post  
Installation Instructions

---

## Heavy Duty Height Adjustable Arm with 3rd Support Post(28-EI-RSRC)

**Notice:** Due to the weight of Diagnostic Monitors, specific heavy duty tilter/vesa plate, arm and mounting cup must be used for this equipment. In addition, a specially designed support post (that correctly accommodates mounting of the heavy duty cup/arm assembly) is also required and must be in place directly beneath the monitor/arm assembly. The instructions below present the specific parts and steps required to mount a larger scale Diagnostic Monitor including instructions for converting an existing support post (part# 28-EI-3-RSRC) that might be used as part of the installation.

**Note:** It is critical and a requirement that any diagnostic monitor in excess of 35 pounds be mounted per these instructions.

## 1. Parts List



28-EI-3-RSRC (either previously purchased or included with this order)



Height Adjustable Arm with Tilter



Height Adjustable Arm Mounting Cup



Heavy duty top portion of the rail clamp



(2) of the M5-0.8X50 DIN 12.9 hardened steel bolts for attaching clamp to the rail



(1) #8 metric 1.25x30mm hardened steel countersunk head screw w/12.9 rating

## 2. ASSEMBLY

1. If you currently have a 28-EI-3-RSRC, remove the two silver screws and top portion of the normal rail clamp. This top portion of the clamp should have two screw holes that ARE NOT recessed and NO center threaded hole. Set aside this top piece and the two silver screws

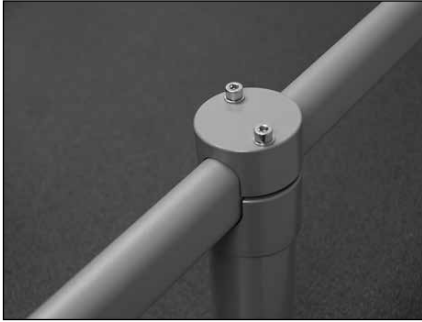

2. Replace the top portion of the clamp with the HD portion using the (2) #4 metric Allen head M5-0.8X50 DIN 12.9 hardened steel bolts in the recessed holes on top of the new HD clamp.



3. Using (1) #8 metric 1.25x30mm hardened steel countersunk head screw, attach the cup portion of the Height Adjustable Arm with a 3/8" Allen wrench to the top clamp. Be sure to position the cup recess over the small steel nipple. Tighten securely to a snug fit.  
Caution: Do not over tighten



---

## 2. ASSEMBLY (cont.)

4. Insert the bottom portion of the Height Adjustable Arm into the cup.



5. Attach the provided 100 X 200 vesa plate to the back of the monitor. Use the factory screws when possible. Note: some monitor models may require the back housing to be removed to accommodate the vesa plate (particularly the Barco 6MP Niofusion)

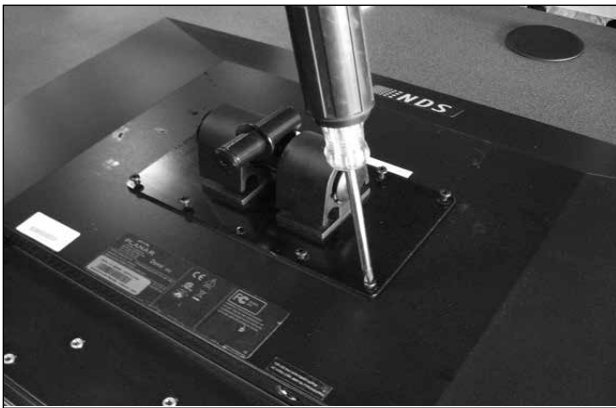

6. The tilter portion of the arm will fit into the top hole of the Height Adjustable Arm. To adjust the tilter use the supplied Allen wrench to tighten or loosen the tilter mechanism for the desired tilt angle of the monitor.

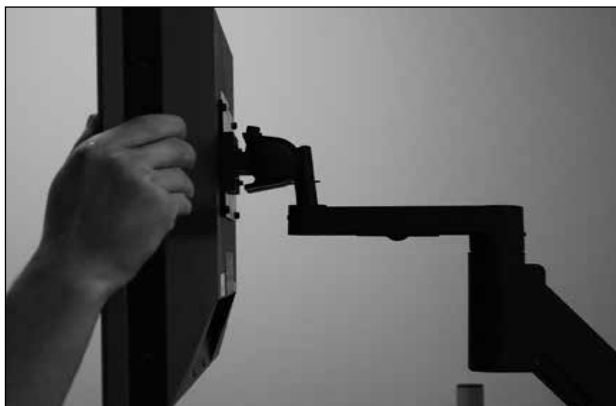

---

## 2. ASSEMBLY (cont.)

7. To calibrate the arm's tension so the monitor will stay in place once positioned, extend the monitor arm fully and position both joints parallel to the desk top. Use the supplied Allen wrench and insert where indicated (with the red arrow). Turn the Allen wrench clockwise to loosen the tension and counterclockwise to tighten the tension. The arm is calibrated when the monitor stays at the level that the user positions it and does not 'drift' when released.

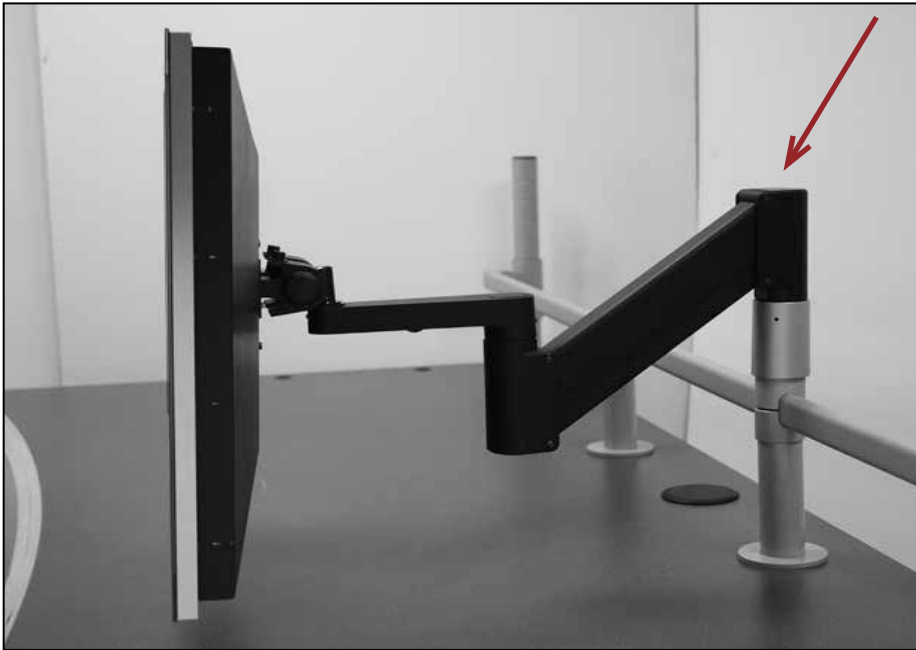

# Certificate of Compliance

Certificate Number 210405 - E254170  
Report Reference E254170, April 1st, 2005  
Issue Date 2005 April 21

Page 1 of 1



*Issued to:*

**LOGICDATA ELECTRONIC & SOFTWARE ENTWICKLUNGS GMBH**

**HINTERLEITENSTR 22A  
A-8523 FRAUENTAL AUSTRIA**

*This is to certify that  
representative samples of*

**Switch mode power supplies for building in**

**LogicS-3-xxxxx-240VA-US; LogicS-3-xxxxx-290VA-US; LogicS-3-xxxxx-340VA-US  
LogicS-3-xxxxx-360VA-US; LogicS-2-xxxxx-240VA-US; LogicS-2-xxxxx-290VA-US  
LogicS-2-xxxxx-340VA-US**

*Have been investigated by Underwriters Laboratories Inc.® in  
accordance with the Standard(s) indicated on this Certificate.*



*Standard(s) for Safety:*

**UL 60950-1 - Information Technology Equipment Safety - Part 1: General  
Requirements  
CSA C22.2 No. 60950-1-Information Technology Equipment Safety - Part 1: General  
Requirements**

*Additional Information:*

Rating(s): All Models: Input 120 V ac, 60 Hz, 6 A;

Only those products bearing the UL Recognized Component Marks for the U.S. and Canada should be considered as being covered by UL's Recognition and Follow-Up Service and meeting the appropriate U.S. and Canadian requirements.

The UL Recognized Component Mark for the U.S. generally consists of the manufacturer's identification and catalog number, model number or other product designation as specified under "Marking" for the particular Recognition as published in the appropriate UL Directory. As a supplementary means of identifying products that have been produced under UL's Component Recognition Program, UL's Recognized Component Mark: , may be used in conjunction with the required Recognized Marks. The Recognized Component Mark is required when specified in the UL Directory preceding the recognitions or under "Markings" for the individual recognitions. The UL Recognized Component Mark for Canada consists of the UL Recognized Mark for Canada:  and the manufacturer's identification and catalog number, model number or other product designation as specified under "Marking" for the particular Recognition as published in the appropriate UL Directory.

**Look for the UL Recognized Component Mark on the product**

Issued by: *Ronni Kulzinger*  
**Ronni Kulzinger, Engineering Team Leader**

UL International Germany GmbH

Any information and documentation provided to you involving UL Mark services are provided on behalf of Underwriters Laboratories Inc.  
For questions in Germany, you may call +49 0 6102 369 0.

Reviewed by: *Andreas Entzeroth*  
**Andreas Entzeroth, Engineering Group Leader**

UL International Germany GmbH



For additional technical information and help,  
contact the following:

Installations-

**Greg Hutchens**

c 205.902.6164

greg.hutchens@coronagroupinc.com.com

Customer Service-

**Alicia Burrows**

p 205.305729.7

alicia.burrow@coronagroupinc.com.com



---

where custom is standard

205.941.1942

Birmingham, AL

info@coronagroupinc.com

coronagroupinc.com